

# Frigoboat Smart Speed Control - SSC

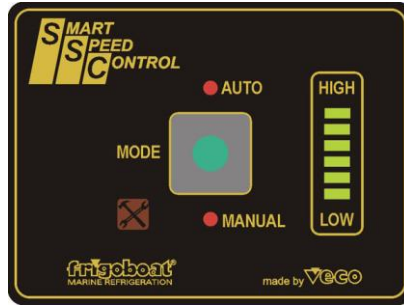

## Discontinued - Options for replacement

The SSC control was phased out several years ago due to increasing costs, and was replaced with first the Merlin I, and then the current Merlin II. Merlin II has the addition of a troubleshooting LED.

Some examples of SSC were found to intermittently keep the compressor running regardless of thermostat setting. This would happen only under a certain combination of circumstances resulting in excessively low box temperatures.

When replacing the SSC with another form of compressor speed control, all wiring associated with the SSC must be completely disconnected and the display abandoned. See wiring diagram over.

### Options:

1. [Speed Board](#) - Plugs onto terminals on compressor controller. Provides manually adjustable compressor speed only.
2. [Merlin II](#) - Plugs onto terminals on compressor controller. Provides automatic compressor speed only. Features compressor speed and troubleshooting LED's.
3. [Guardian](#) - Remote panel incorporating Coastal MK II digital thermostat plus manual compressor speed control knob and troubleshooting LED. Has 10' wiring harness.
4. [Guardian + Merlin II](#) - Gives option of either manual or automatic compressor speed control.

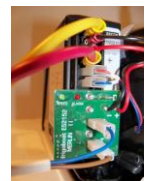

Why alter compressor speed? [See here.](#)

# Smart Speed Control Wiring Instructions

Wiring shown is for Mechanical Thermostat, plus optional "Carel" and "Coastal 1" digital thermostat/thermometers. "Coastal II" is same order, different terminal numbers.

## Mechanical Thermostat

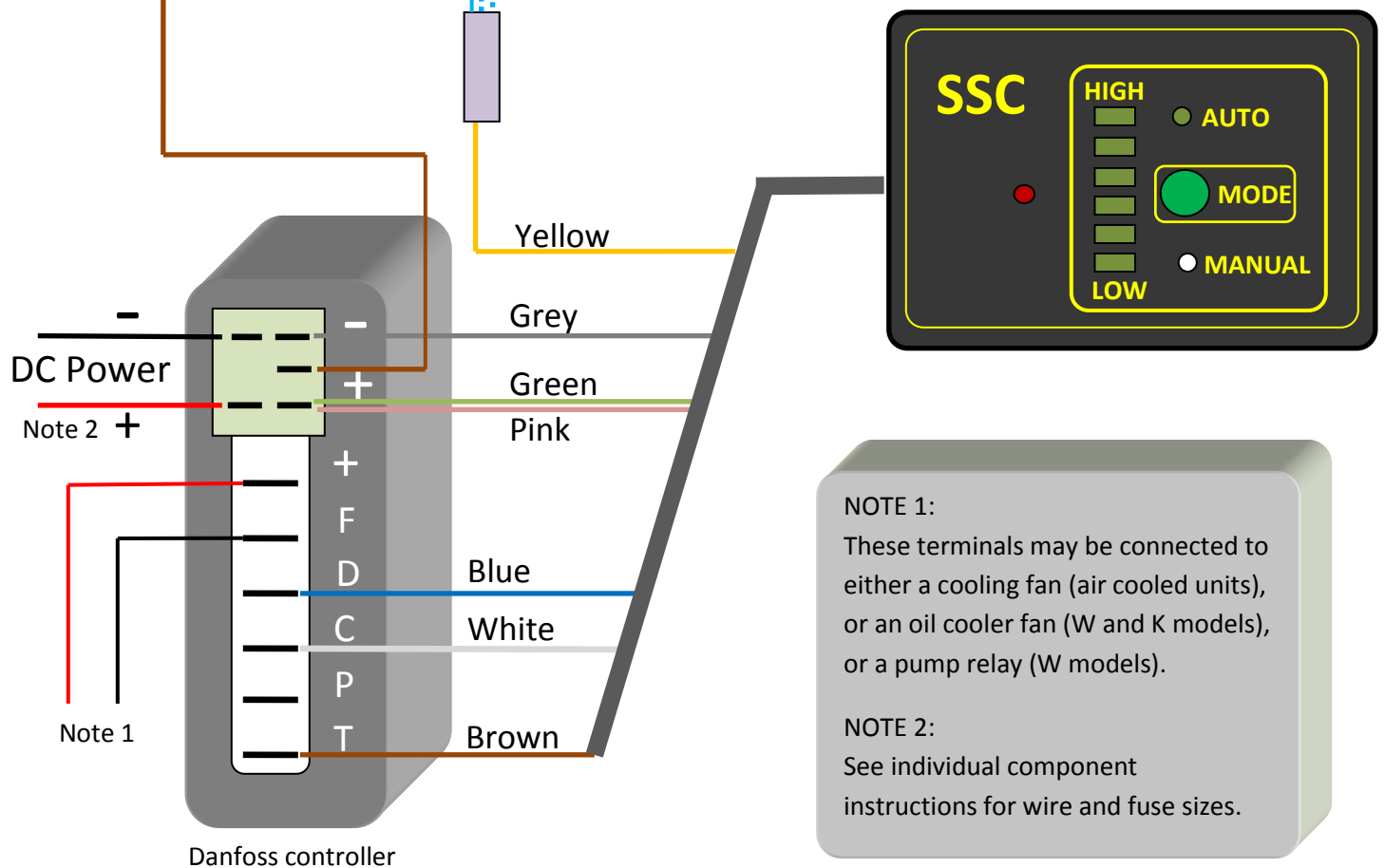
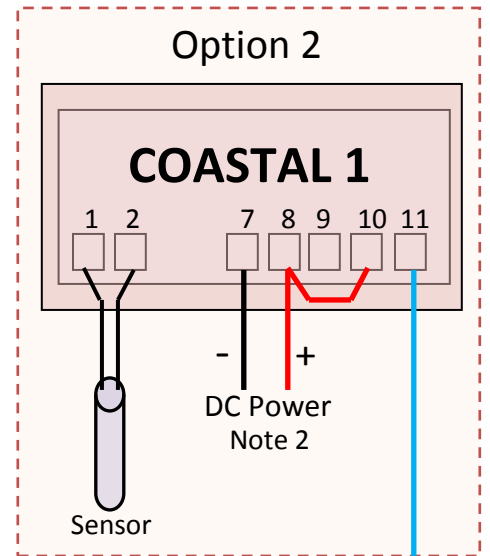
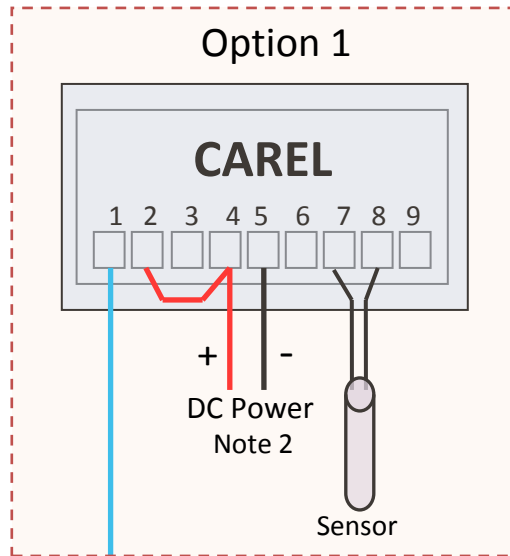
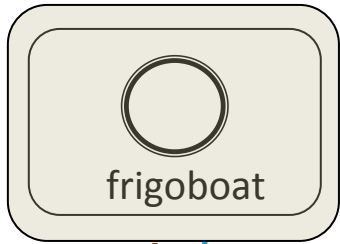

### NOTE 1:

These terminals may be connected to either a cooling fan (air cooled units), or an oil cooler fan (W and K models), or a pump relay (W models).

### NOTE 2:

See individual component instructions for wire and fuse sizes.